

REVISION HISTORY				
REV.	DESCRIPTION	DATE	ECO	BY

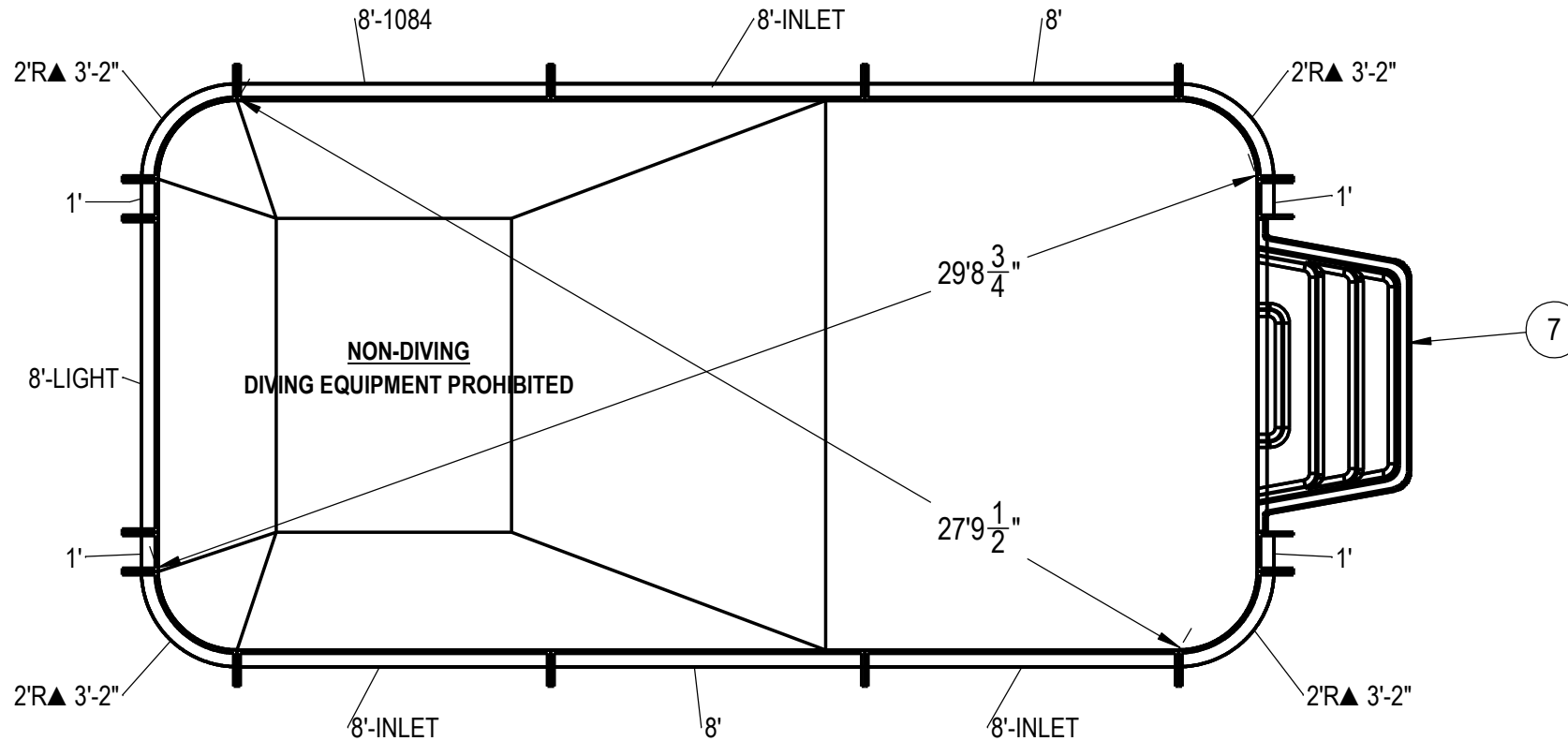

**NON-DIVING  
DIVING EQUIPMENT PROHIBITED**

**NOTES:**

- THESE ARE FINISHED DIMENSIONS READY FOR THE LINER.
- DIMENSIONS ARE FROM INSIDE POOL PANELS.
- ROPE AND FLOAT ASSEMBLY SHOULD BE INSTALLED IN ACCORDANCE WITH CURRENT ANSI/ASPS/ICC REGULATIONS
- HYDRA LINER TRACK FOR STEPS IS INSTALLED WITH THE BARB FACING THE RISER WALL ON THE STEP.

**EXCAVATION NOTES:**

- ROUGH EXCAVATION SHOULD BE 2" DEEPER IN EACH INSTANCE.
- SOIL TO HAVE MINIMUM BEARING CAPACITY OF 1500 PSF.
- LOCATE TOP OF POOL AT LEAST 6" ABOVE THE SURROUNDING LAND ELEVATION.
- SEE "OVER DIG DETAIL" FOR EXCAVATION AROUND POOL.
- FILL VOIDS UNDER BASE OF PANELS AND TAMP WELL.
- BACK FILL WITH NON-EXPANSIVE MATERIAL.
- FOLLOW ALL CURRENT ANSI / APSP / ICC GUIDELINES FOR RESIDENTIAL POOLS

**IMPORTANT NOTES:**

THIS DOCUMENT IS FOR ILLUSTRATIVE PURPOSES ONLY. THE DEALER OR CONTRACTOR WHO SELLS OR INSTALLS YOUR POOL IS AN INDEPENDENT CONTRACTOR AND IS NOT AN AGENT OF THE MANUFACTURER. THE CONSTRUCTION METHODS ILLUSTRATED HERE ARE SUGGESTIONS AND APPLY ONLY TO NORMAL GROUND CONDITIONS. THERE MAY BE ADDITIONAL PRECAUTIONS AND/OR METHODS OF CONSTRUCTION. PROPER INSTALLATION IS THE RESPONSIBILITY OF THE DEALER/BUILDER/CONTRACTOR.

ITEM	FILE NAME	DESCRIPTION	CUSTOMER DRAWING #	VENDOR PART #	QTY.
1	PANEL, STRAIGHT	PANEL, 8' LONG, 1084, 700 SERIES	HPSE10884	00004966	1
2	PANEL, STRAIGHT	PANEL, 8' LONG, INLET, 700 SERIES	HPSE108I	00004969	3
3	PANEL, STRAIGHT	PANEL, 8' LONG, 700 SERIES	HPSE108P	00004961	2
4	PANEL, STRAIGHT	PANEL, 1' LONG, 700 SERIES	HPSE101P	00002469	4
5	PANEL, STRAIGHT	PANEL, 8' LONG, LIGHT, 700 SERIES	HPSE108L	00004962	1
6	PANEL, RADIUS	PANEL, 2' RADIUS, 3-2" LONG, 700 SERIES	HPSE2R	00002541	4
7	HS110N	STEP, 8', TWIN SEAT, 4 TREAD	HS110N	HS110N	1
8	SBRACE	BRACE, FOLD OVER WITH TURNBUCKLE, STEEL, HPSFOB	HPSFOB	HPSFOB	16
9	BOLT, PACK	BOLT, FLANGE, 3/8-16 X 1", PACK (50)	HPS1916	HPS1916	4

ENGINEERING DRAWING NUMBER:  
**00018123**

WEIGHT: lbs	UNLESS OTHERWISE SPECIFIED DIMENSIONS ARE IN INCHES TOLERANCES DECIMALS: X ± .1 XX ± .01 XXX ± .001 XXXX ± .0005  ANGULAR: X ± 0.5 THIRD ANGLE PROJECTION
VOLUME: Inch <sup>3</sup>	
COLOR:	
HEAT TREAT:	
FINISH:	
TEXTURE:	

DESIGNED BY: <b>BUMPHREY</b>	CREATION DATE: <b>6/4/2013</b>
DETAILED BY: <b>JRITTENHOUSE</b>	DETAILED DATE: <b>4/4/2018</b>
LAST REVISED BY: <b>rhouston</b>	LAST REVISED DATE: <b>4/4/2018</b>
MATERIAL:	

**HYDRA POOLS**

TITLE: **LAYOUT, 14' X 28', RECTANGLE, 2' RADIUS, 6' DEEP, HS110N, LIGHT, 1084, 3-INLET, 700 SERIES**

PART NUMBER: **00018123**

SCALE: **1:96**      SIZE: **A**  
SHEET: **1 OF 3**

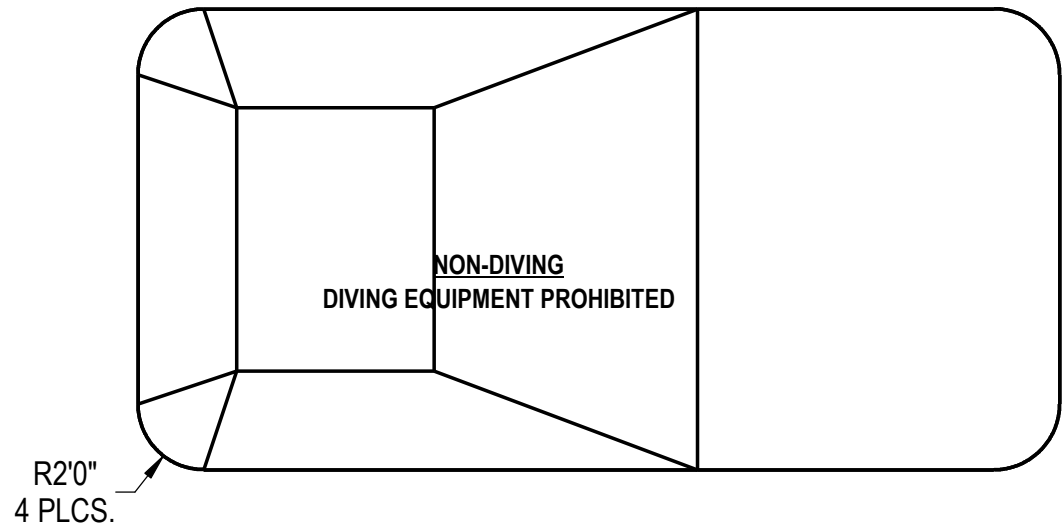
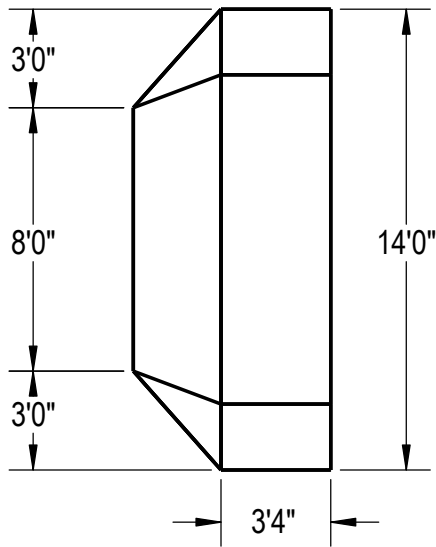

**Area: 388.57ft ^2**  
**Perimeter: 80.57ft**  
**Volume = 12311 US gallons**

**NOTES:**

1. THESE ARE FINISHED DIMENSIONS READY FOR THE LINER.
2. DIMENSIONS ARE FROM INSIDE POOL PANELS.
3. ROPE AND FLOAT ASSEMBLY SHOULD BE INSTALLED IN ACCORDANCE WITH CURRENT ANSI/ASPS/CC REGULATIONS
4. HYDRA LINER TRACK FOR STEPS IS INSTALLED WITH THE BARB FACING THE RISER WALL ON THE STEP.

**EXCAVATION NOTES:**

5. ROUGH EXCAVATION SHOULD BE 2" DEEPER IN EACH INSTANCE.
6. SOIL TO HAVE MINIMUM BEARING CAPACITY OF 1500 PSF.
7. LOCATE TOP OF POOL AT LEAST 6" ABOVE THE SURROUNDING LAND ELEVATION.
8. SEE "OVER DIG DETAIL" FOR EXCAVATION AROUND POOL.
9. FILL VOIDS UNDER BASE OF PANELS AND TAMP WELL.
10. BACK FILL WITH NON-EXPANSIVE MATERIAL.
11. FOLLOW ALL CURRENT ANSI / APSP / ICC GUIDELINES FOR RESIDENTIAL POOLS

**IMPORTANT NOTES:**

THIS DOCUMENT IS FOR ILLUSTRATIVE PURPOSES ONLY. THE DEALER OR CONTRACTOR WHO SELLS OR INSTALLS YOUR POOL IS AN INDEPENDENT CONTRACTOR AND IS NOT AN AGENT OF THE MANUFACTURER. THE CONSTRUCTION METHODS ILLUSTRATED HERE ARE SUGGESTIONS AND APPLY ONLY TO NORMAL GROUND CONDITIONS. THERE MAY BE ADDITIONAL PRECAUTIONS AND/OR METHODS OF CONSTRUCTION. PROPER INSTALLATION IS THE RESPONSIBILITY OF THE DEALER/BUILDER/CONTRACTOR.

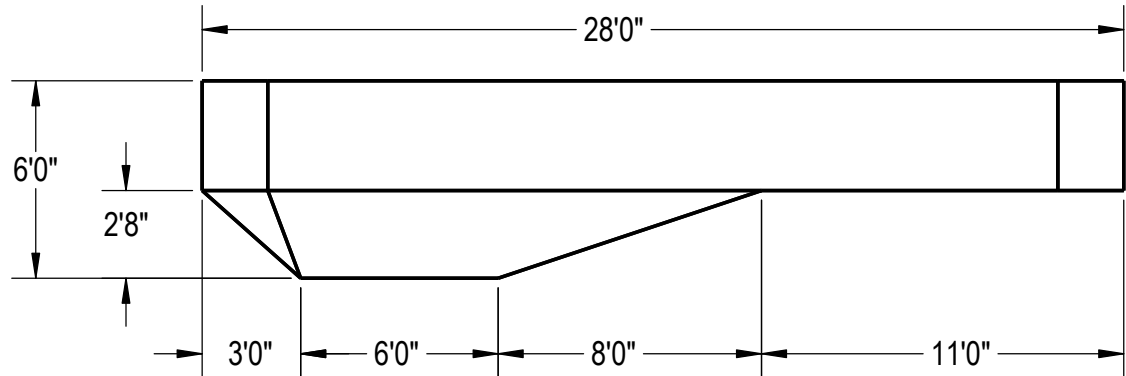

ENGINEERING DRAWING NUMBER: <b>00018123</b>	WEIGHT:	UNLESS OTHERWISE SPECIFIED DIMENSIONS ARE IN INCHES TOLERANCES DECIMALS: X ± .1 XX ± .01 XXX ± .001 XXXX ± .0005  ANGULAR: X ± 0.5 THIRD ANGLE PROJECTION	DESIGNED BY:	CREATION DATE:	<b>HYDRA POOLS</b>		
	lbs		<b>BUMPHREY</b>	<b>6/4/2013</b>			
	VOLUME:		Detailed by:	DETAILED DATE:			
	Inch <sup>3</sup>		<b>JRITTENHOUSE</b>	<b>4/4/2018</b>			
NA	COLOR:	LAST REVISED BY:	LAST REVISED DATE:	TITLE:	<b>LAYOUT, 14' X 28', RECTANGLE, 2' RADIUS, 6' DEEP, HS110N, LIGHT, 1084, 3-INLET, 700 SERIES</b>		
NA	HEAT TREAT:	<b>rhouston</b>	<b>4/4/2018</b>	PART NUMBER:			
NA	FINISH:	MATERIAL:			SCALE:	SIZE:	
NA	TEXTURE:			<b>00018123</b>		<b>1:96</b>	<b>A</b>
						SHEET:	
						<b>2 OF 3</b>	

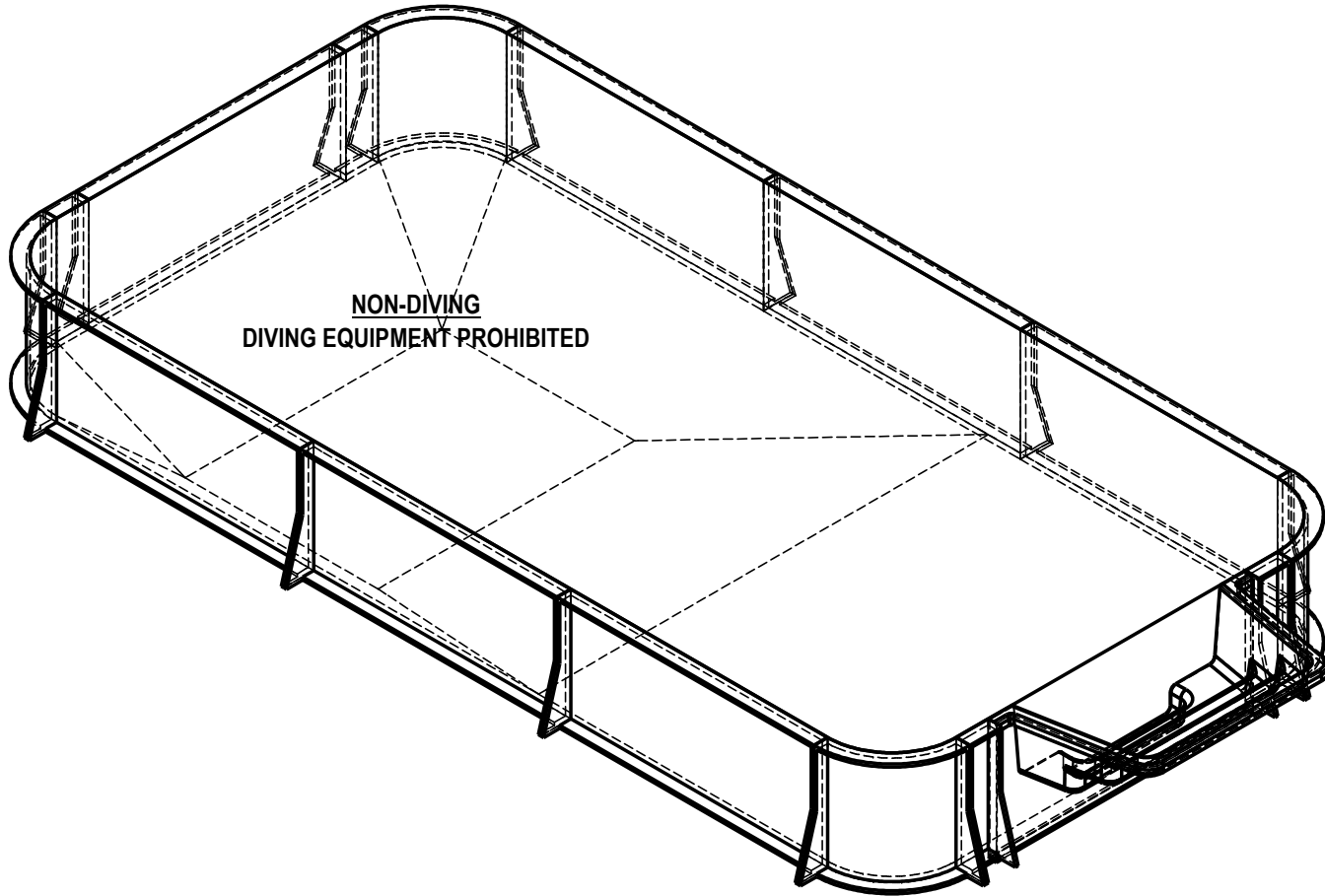

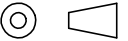
ENGINEERING DRAWING NUMBER: <b>00018123</b>	WEIGHT:	<b>UNLESS OTHERWISE SPECIFIED</b> DIMENSIONS ARE IN INCHES TOLERANCES DECIMALS: X ± .1 XX ± .01 XXX ± .001 XXXX ± .0005  ANGULAR: X ± 0.5 THIRD ANGLE PROJECTION 	DESIGNED BY:	CREATION DATE:	<b>HYDRA POOLS</b>	
	lbs		<b>BUMPHREY</b>	<b>6/4/2013</b>		
	VOLUME:		Detailed by:	DETAILED DATE:	TITLE: <b>LAYOUT, 14' X 28', RECTANGLE, 2' RADIUS, 6' DEEP, HS110N, LIGHT, 1084, 3-INLET, 700 SERIES</b>	
	Inch <sup>3</sup>		<b>JRITTENHOUSE</b>	<b>4/4/2018</b>		
	COLOR:		LAST REVISED BY:	LAST REVISED DATE:		
	NA		<b>rhouston</b>	<b>4/4/2018</b>		
HEAT TREAT:	MATERIAL:	PART NUMBER:	SCALE:	SIZE:		
NA		<b>00018123</b>	<b>1:96</b>	<b>A</b>		
FINISH:			SHEET:			
NA			<b>3 OF 3</b>			
TEXTURE:						
NA						