

REVISION HISTORY				
REV.	DESCRIPTION	DATE	ECO	BY

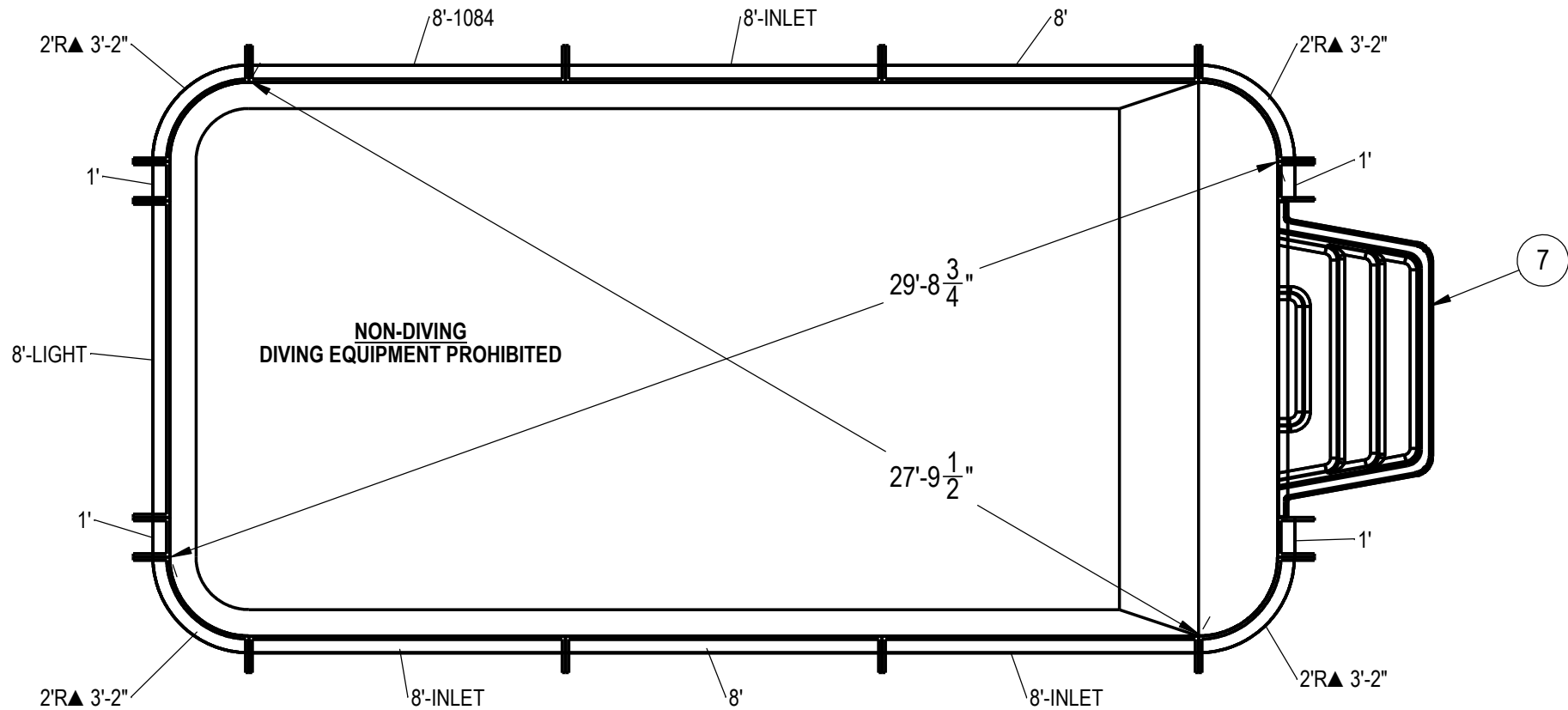

NOTES:

- THESE ARE FINISHED DIMENSIONS READY FOR THE LINER.
- DIMENSIONS ARE FROM INSIDE POOL PANELS.
- ROPE AND FLOAT ASSEMBLY SHOULD BE INSTALLED IN ACCORDANCE WITH CURRENT ANSI/ASPS/ICC REGULATIONS
- HYDRA LINER TRACK FOR STEPS IS INSTALLED WITH THE BARB FACING THE RISER WALL ON THE STEP.

EXCAVATION NOTES:

- ROUGH EXCAVATION SHOULD BE 2" DEEPER IN EACH INSTANCE.
- SOIL TO HAVE MINIMUM BEARING CAPACITY OF 1500 PSF.
- LOCATE TOP OF POOL AT LEAST 6" ABOVE THE SURROUNDING LAND ELEVATION.
- SEE "OVER DIG DETAIL" FOR EXCAVATION AROUND POOL.
- FILL VOIDS UNDER BASE OF PANELS AND TAMP WELL.
- BACK FILL WITH NON-EXPANSIVE MATERIAL.
- FOLLOW ALL CURRENT ANSI / APS / ICC GUIDELINES FOR RESIDENTIAL POOLS

IMPORTANT NOTES:

THIS DOCUMENT IS FOR ILLUSTRATIVE PURPOSES ONLY. THE DEALER OR CONTRACTOR WHO SELLS OR INSTALLS YOUR POOL IS AN INDEPENDENT CONTRACTOR AND IS NOT AN AGENT OF THE MANUFACTURER. THE CONSTRUCTION METHODS ILLUSTRATED HERE ARE SUGGESTIONS AND APPLY ONLY TO NORMAL GROUND CONDITIONS. THERE MAY BE ADDITIONAL PRECAUTIONS AND/OR METHODS OF CONSTRUCTION. PROPER INSTALLATION IS THE RESPONSIBILITY OF THE DEALER/BUILDER/CONTRACTOR.

ITEM	FILE NAME	DESCRIPTION	CUSTOMER DRAWING #	VENDOR PART #	QTY.
1	PANEL, RADIUS	PANEL, 2' RADIUS, 3-2" LONG, 700 SERIES	HPSE2R	00002541	4
2	PANEL, STRAIGHT	PANEL, 8' LONG, LIGHT, 700 SERIES	HPSE108L	00004962	1
3	PANEL, STRAIGHT	PANEL, 8' LONG, INLET, 700 SERIES	HPSE108I	00004969	3
4	PANEL, STRAIGHT	PANEL, 8' LONG, 700 SERIES	HPSE108P	00004961	2
5	PANEL, STRAIGHT	PANEL, 8' LONG, 1084, 700 SERIES	HPSE10884	00004966	1
6	PANEL, STRAIGHT	PANEL, 1' LONG, 700 SERIES	HPSE101P	00002469	4
7	HS110N	STEP, 8', TWIN SEAT, 4 TREAD	HS110N	HS110N	1
8	BOLT, PACK	BOLT, FLANGE, 3/8-16 X 1", PACK (50)	HPS1916	HPS1916	4
9	SBRACE	BRACE, FOLD OVER WITH TURNBUCKLE, STEEL, HPSFOB	HPSFOB	HPSFOB	16

ENGINEERING DRAWING NUMBER: 00018140	WEIGHT:	UNLESS OTHERWISE SPECIFIED DIMENSIONS ARE IN INCHES TOLERANCES DECIMALS: X ± .1 XX ± .01 XXX ± .001 XXXX ± .0005 ANGULAR: X ± 0.5 THIRD ANGLE PROJECTION	DESIGNED BY: BUMPHREY	CREATION DATE: 4/9/2013	HYDRA POOLS			
	VOLUME: Inch ³		DETAILED BY: JRITTENHOUSE	DETAILED DATE: 4/4/2018				
	COLOR:		LAST REVISED BY: rhouston	LAST REVISED DATE: 4/4/2018	TITLE: LAYOUT, 14' X 28', RECTANGLE, 2' RADIUS, 4' DEEP, FLAT BOTTOM, HS110N, 1084, 3-INLET, 700 SERIES			
	HEAT TREAT:		MATERIAL:	PART NUMBER: 00018140			SCALE: 1:128	SIZE: A
	FINISH:			SHEET: 1 OF 3				
TEXTURE:								

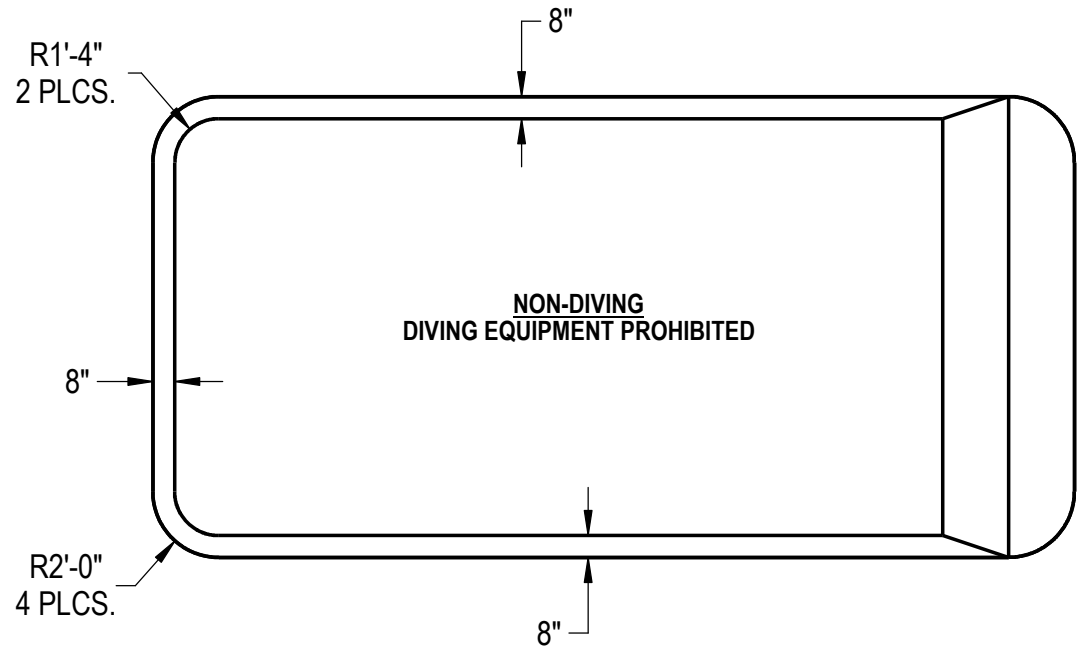
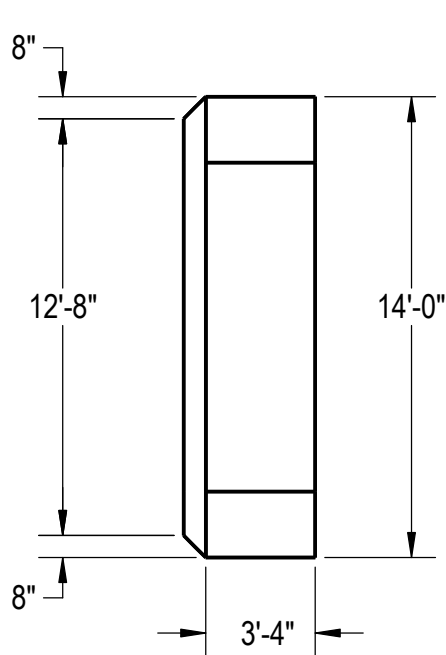

Area: 388.57ft ²
Perimeter: 80.57ft
Volume = 11325 US gallons

NOTES:

1. THESE ARE FINISHED DIMENSIONS READY FOR THE LINER.
2. DIMENSIONS ARE FROM INSIDE POOL PANELS.
3. ROPE AND FLOAT ASSEMBLY SHOULD BE INSTALLED IN ACCORDANCE WITH CURRENT ANSI/ASPS/ICC REGULATIONS
4. HYDRA LINER TRACK FOR STEPS IS INSTALLED WITH THE BARB FACING THE RISER WALL ON THE STEP.

EXCAVATION NOTES:

5. ROUGH EXCAVATION SHOULD BE 2" DEEPER IN EACH INSTANCE.
6. SOIL TO HAVE MINIMUM BEARING CAPACITY OF 1500 PSF.
7. LOCATE TOP OF POOL AT LEAST 6" ABOVE THE SURROUNDING LAND ELEVATION.
8. SEE "OVER DIG DETAIL" FOR EXCAVATION AROUND POOL.
9. FILL VOIDS UNDER BASE OF PANELS AND TAMP WELL.
10. BACK FILL WITH NON-EXPANSIVE MATERIAL.
11. FOLLOW ALL CURRENT ANSI / APSP / ICC GUIDELINES FOR RESIDENTIAL POOLS

IMPORTANT NOTES:

THIS DOCUMENT IS FOR ILLUSTRATIVE PURPOSES ONLY. THE DEALER OR CONTRACTOR WHO SELLS OR INSTALLS YOUR POOL IS AN INDEPENDENT CONTRACTOR AND IS NOT AN AGENT OF THE MANUFACTURER. THE CONSTRUCTION METHODS ILLUSTRATED HERE ARE SUGGESTIONS AND APPLY ONLY TO NORMAL GROUND CONDITIONS. THERE MAY BE ADDITIONAL PRECAUTIONS AND/OR METHODS OF CONSTRUCTION. PROPER INSTALLATION IS THE RESPONSIBILITY OF THE DEALER/BUILDER/CONTRACTOR.

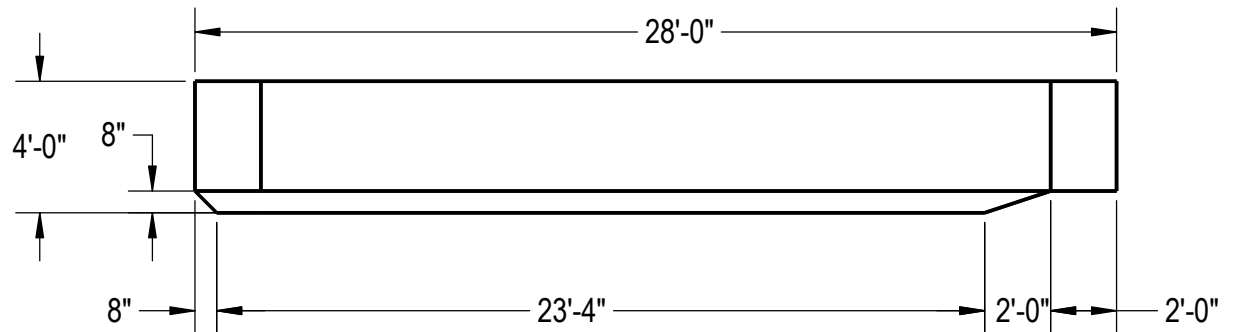

ENGINEERING DRAWING NUMBER: 00018140	WEIGHT:	UNLESS OTHERWISE SPECIFIED DIMENSIONS ARE IN INCHES TOLERANCES DECIMALS: X ± .1 XX ± .01 XXX ± .001 XXXX ± .0005 ANGULAR: X ± 0.5 THIRD ANGLE PROJECTION	DESIGNED BY:	CREATION DATE:	HYDRA POOLS		
	lbs		BUMPHREY	4/9/2013			
	VOLUME:			DETAILED BY:	DETAILED DATE:	TITLE: LAYOUT, 14' X 28', RECTANGLE, 2' RADIUS, 4' DEEP, FLAT BOTTOM, HS110N, 1084, 3-INLET, 700 SERIES	
	Inch ³			JRITTENHOUSE	4/4/2018		
	COLOR:			LAST REVISED BY:	LAST REVISED DATE:		
NA		rhouston	4/4/2018	SCALE: 1:128	SIZE: A		
HEAT TREAT:		MATERIAL:		SHEET: 2 OF 3			
NA							
FINISH:							
NA							
TEXTURE:							
NA							

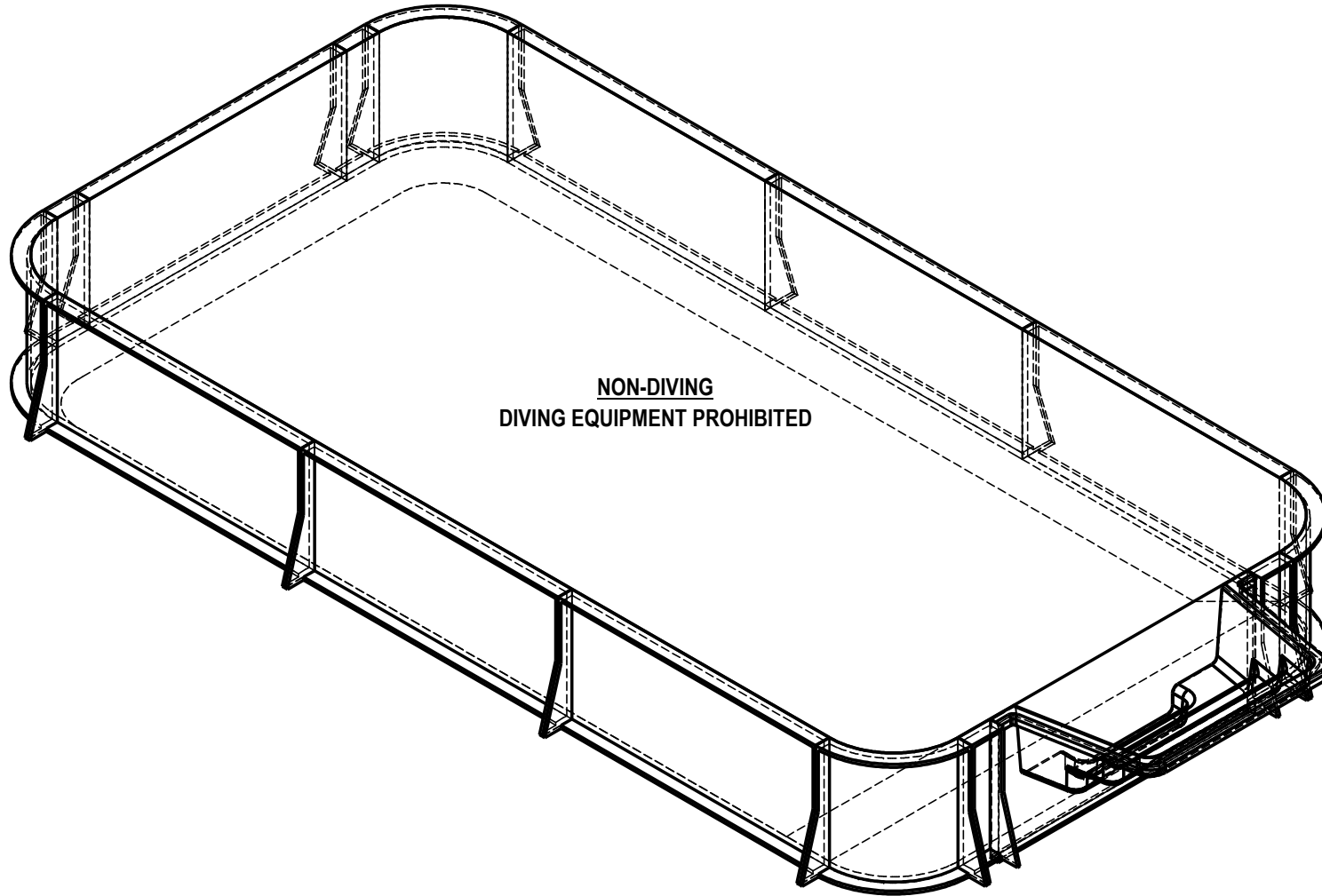

**NON-DIVING
DIVING EQUIPMENT PROHIBITED**

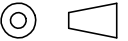
ENGINEERING DRAWING NUMBER: 00018140	WEIGHT:	UNLESS OTHERWISE SPECIFIED DIMENSIONS ARE IN INCHES TOLERANCES DECIMALS: X ± .1 XX ± .01 XXX ± .001 XXXX ± .0005 ANGULAR: X ± 0.5 THIRD ANGLE PROJECTION 	DESIGNED BY:	CREATION DATE:	HYDRA POOLS
	lbs		BUMPHREY	4/9/2013	
	VOLUME:		DETAILED BY:	DETAILED DATE:	
	Inch ³		JRITTENHOUSE	4/4/2018	TITLE: LAYOUT, 14' X 28', RECTANGLE, 2' RADIUS, 4' DEEP, FLAT BOTTOM, HS110N, 1084, 3-INLET, 700 SERIES
	COLOR:		LAST REVISED BY:	LAST REVISED DATE:	PART NUMBER: 00018140
	HEAT TREAT:		rhouston	4/4/2018	
FINISH:	MATERIAL:		SHEET: 3 OF 3	SIZE: A	
TEXTURE:					